

**ELTEK**  
GROUP

An Organization at Your Service

# Appliance



10.0418

*Dispensatore  
integrato*

*Integrated  
dispenser*

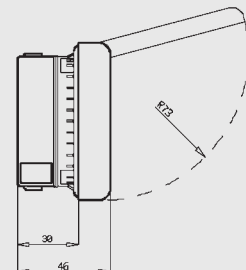
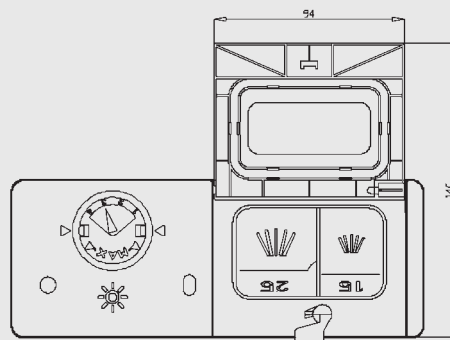
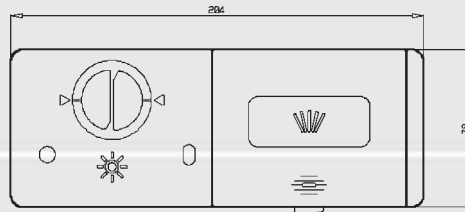

## Dispensatore integrato

## Integrated dispenser

# Appliance



### Dati Tecnici



### Technical Data

**10.0418**

Tempo di alimentazione	Power supply time	30/60 sec
Temperatura ambiente massima	Max ambient temperature	70°C
Tensione di alimentazione	Voltage	12-24 V a.c./d.c.; 110-240 V a.c.
Terminali	Terminals	6,3x0,8 mm
Capacità vaschette detersivo	Detergent cup capacity	- prelavaggio/pre-wash: max 8 ml - lavaggio/wash: da 15 a 40 ml/from 15 to 40 ml
Regolazione brillantante	Rinse-aid dispensing	Manuale: sono disponibili 4 posizioni del regolatore dell'erogazione brillantante Manual: 4 positions to dispense rinse aid are possible
Capacità serbatoio di scorta del brillantante	Rinse-aid chamber capacity	120 cc (corrisponde all'indicazione "MAX") 120 cc (filling it up to "MAX" indicated in the rinse aid fill chamber)
Indicatore livello brillantante	Indication of the rinse aid level	Visivo/reed (circa 40 ml di brillantante residuo); visual/reed (approx 40 ml rinse aid left)
Dimensioni trancio controporta	Dimension inner door panel cut out	Lunghezza/length: 194 mm Larghezza/width: 68 mm Raggio di raccordo/radius: R= 7 mm
Normative di riferimento	Reference standards	EN 60730-1, EN 60730-2-14
Approvazioni	Approvals	ENEC, UL, CSA



ISO 9001:2000



ISO/TS 16949



ISO 14001:2004

ELTEK S.p.a.

strada Valenza 5A - 15033 Casale M.to (AL) - Italy  
Tel. 0142/335511 - Fax 0142/335555 - 0142/335666

[www.eltekgroup.it](http://www.eltekgroup.it)